

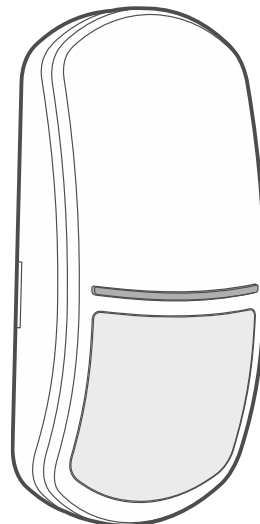

Motion Detector Pet  
**APD-200 Pet**

Firmware version 1.04

**EN**



**CE**

apd-200\_pet\_BW\_en 01/26

## IMPORTANT

Changes, modifications or repairs not authorized by the manufacturer shall void your rights under the warranty.

Description of symbols on the device:



The device meets the requirements of the applicable EU directives.



The device must not be disposed of with other municipal waste. It should be disposed of in accordance with the existing rules for environment protection (the device was placed on the market after 13 August 2005).



The device is designed for indoor installation.

SATEL aims to continually improve the quality of its products, which may result in changes in their technical specifications and software. Current information about the changes being introduced is available on our website.

Please visit us at:  
<https://support.satel.pl>

**Hereby, SATEL sp. z o.o. declares that the radio equipment type APD-200 Pet is in compliance with Directive 2014/53/EU. The full text of the EU declaration of conformity is available at the following internet address: [www.satel.pl/ce](http://www.satel.pl/ce)**

### Signs in this manual



Caution – information on the safety of users, devices, etc.



Note – suggestion or additional information.

## CONTENTS

1. Features .....	2
2. Description .....	2
3. Installation .....	3
3.1 Tips for installation .....	4
3.2 Mounting .....	5
4. Test .....	7
5. Battery replacement .....	8
6. Specifications .....	8

The APD-200 Pet detector (Motion Detector Pet) uses infrared to detect motion. It ignores moving pets up to 20 kilos. The manual applies to the detector installed in the BE WAVE system.

## 1. Features

---

- Motion detection using passive infrared sensor (PIR).
- Maximum coverage area: 14 m x 16 m, 83° (Fig. 6).
- Digital motion detection algorithm.
- Digital temperature compensation.
- Operation in the 868 MHz frequency band.
- AES encrypted two-way radio communication.
- Transmission channel diversity – 4 channels for automatic selection of the one that will enable transmission without interference with other signals.
- Remote settings programming.
- Remote firmware update.
- Built-in temperature sensor (measuring range: -10 °C...+55°C).
- LED indicators.
- Supervision of motion detection system.
- Powered by CR123A 3 V battery.
- Battery status control.
- Tamper protection against enclosure opening and removal from mounting surface.

## 2. Description

---

### Alarms

The detector reports alarm after:

- detecting motion in the protected area,
- detecting a fault in the motion detection system,
- opening the tamper switch (tamper alarm).

### Electronics module

Figure 1 shows the detector electronics module.

- ① battery holder (CR123A 3 V).
- ② LED indicators. They are flashing for about 35 seconds after inserting the battery (detector warm-up). After that, they are only enabled while the diagnostics mode is started in the system. They indicate:
  - periodical communication – short flash.
  - alarm – ON for 2 seconds.
- ③ tamper switch activated by enclosure opening.
- ④ PIR sensor (dual element pyrosensor).

On the other side of the electronics module is a tamper switch activated by removing the detector base from the surface.

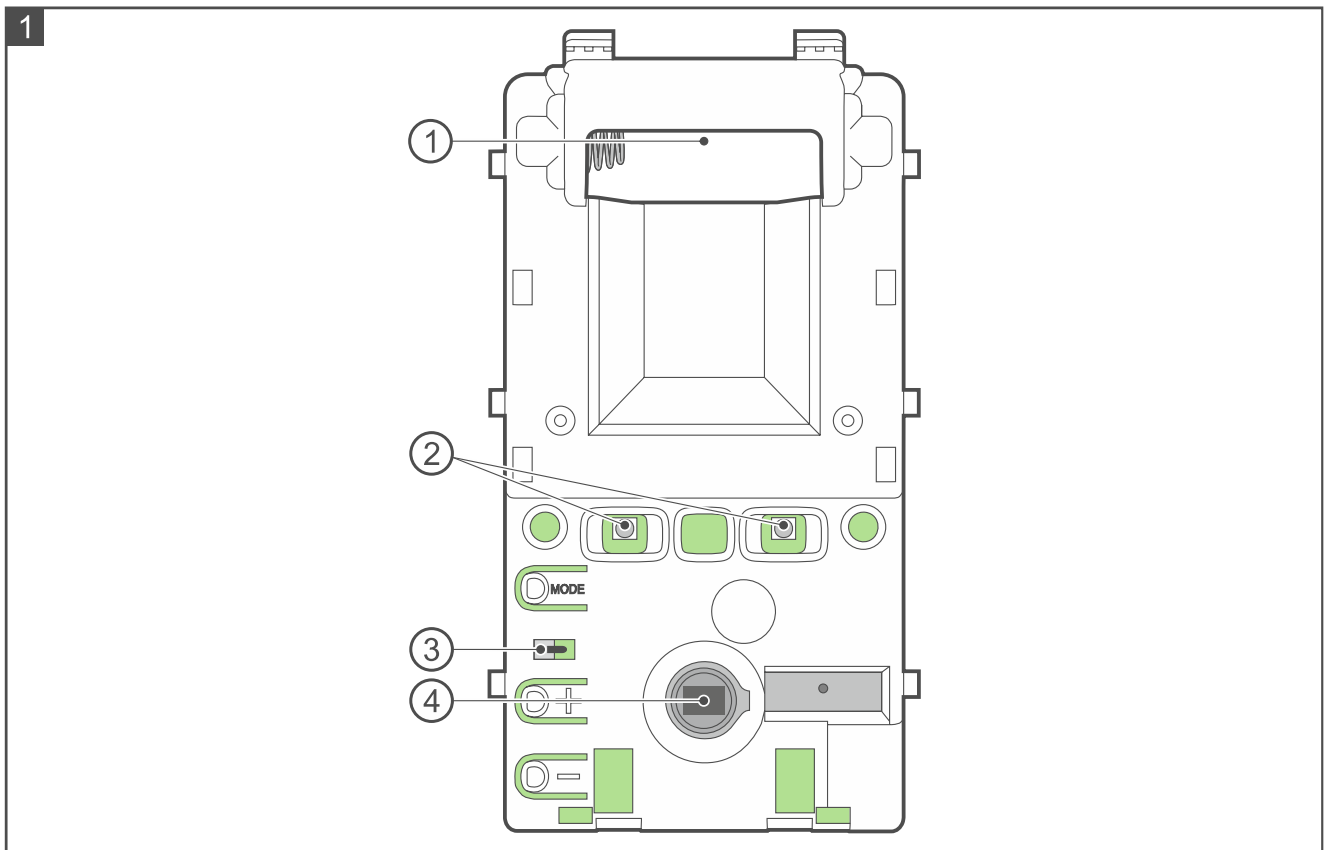

### 3. Installation



There is a danger of battery explosion when using a different battery than recommended by the manufacturer, or handling the battery improperly.

Do not crush the battery, cut it or expose it to high temperatures (throw it into the fire, put it in the oven, etc.).

Do not expose the battery to very low pressure due to the risk of battery explosion or leakage of flammable liquid or gas.

Be particularly careful during installation and replacement of the battery. The manufacturer is not liable for the consequences of incorrect installation of the battery.

If the detector is mounted higher than 2 meters above the ground, it may cause harm if it falls off.

### 3.1 Tips for installation

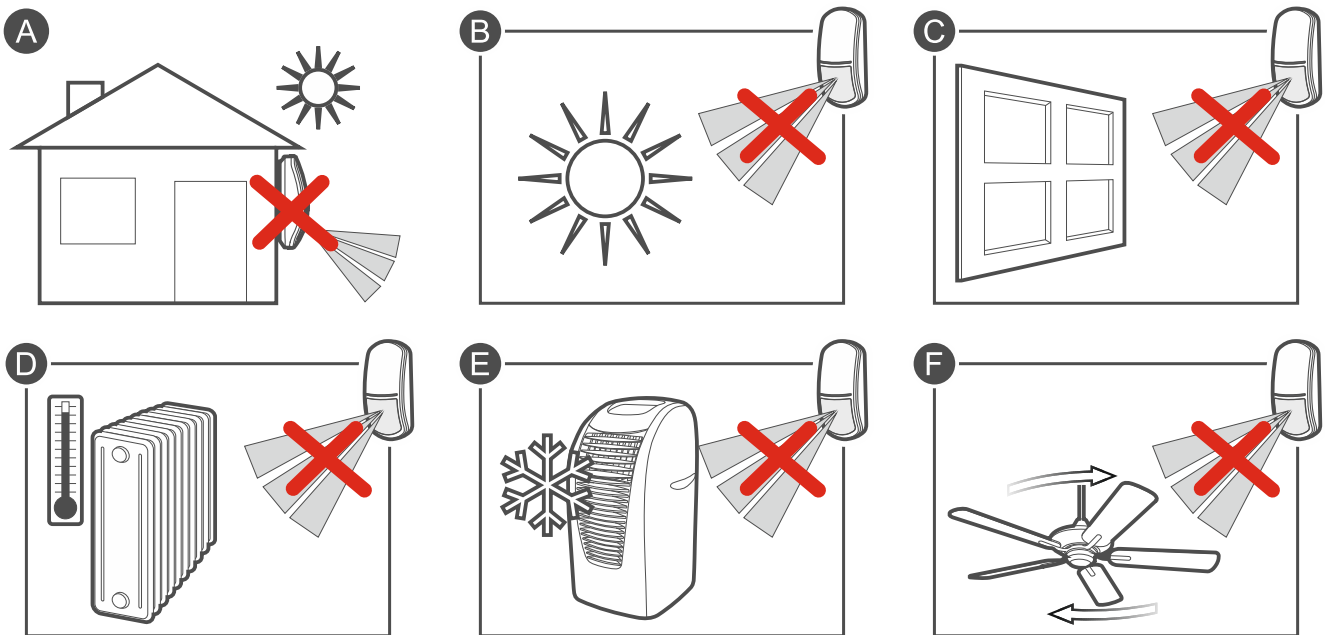

- The detector should be installed indoors, in spaces with normal air humidity.
- Do not install the detector outdoors (A).
- When selecting a place of installation, consider the radio communication range.
- Thick walls, metal partitions, etc. reduce the range of the radio signal.
- Do not aim the detector directly at sunlight or at surfaces reflecting sunlight (B).
- Do not aim the detector at a window because it may detect motion on the outside (C).
- Do not point the detector towards heat sources (D), air conditioners (E) or fans (F).
- No object should obstruct the detector's field of view.
- Install the detector at the recommended height: 2.4 m.
- If you are using a double-sided mounting tape, remember to press it properly. Stick the tape to the device and keep pressing for several seconds, then stick the device to the surface and keep pressing for several seconds.



*The detector is pet immune when it is mounted at 2.4 m height with no vertical tilt.*

## 3.2 Mounting

1. Remove the front cover (Fig. 2).



The inside of the cover and the electronics module of the detector are marked with a blue circle. This makes it easier to identify the elements of the device.

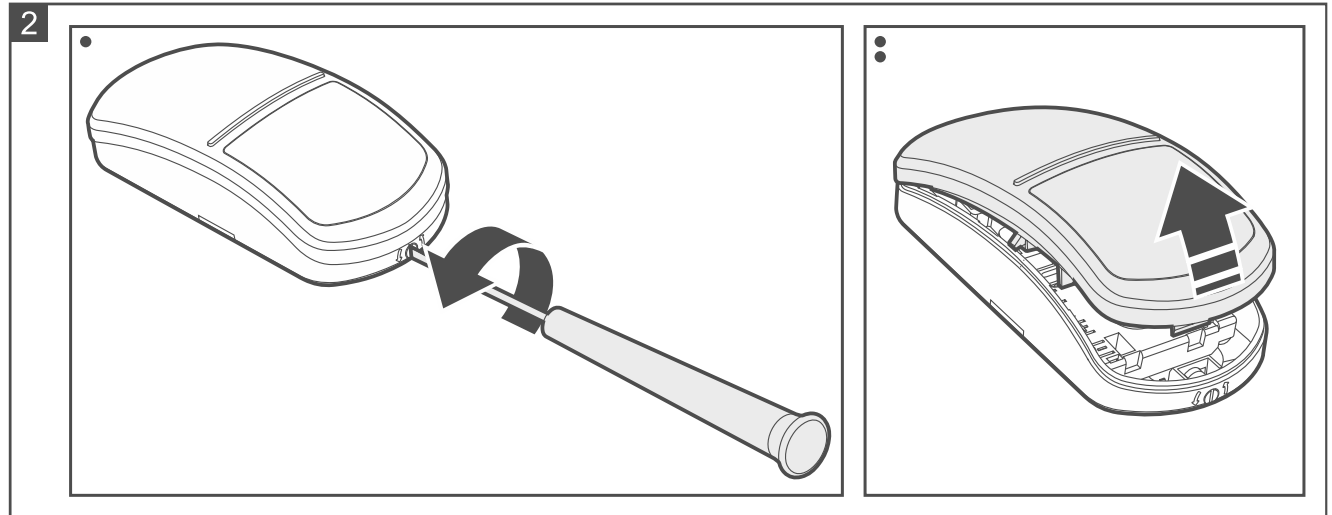

2. Press the catches and move the electronics module down, then remove it from the enclosure base (Fig. 3).

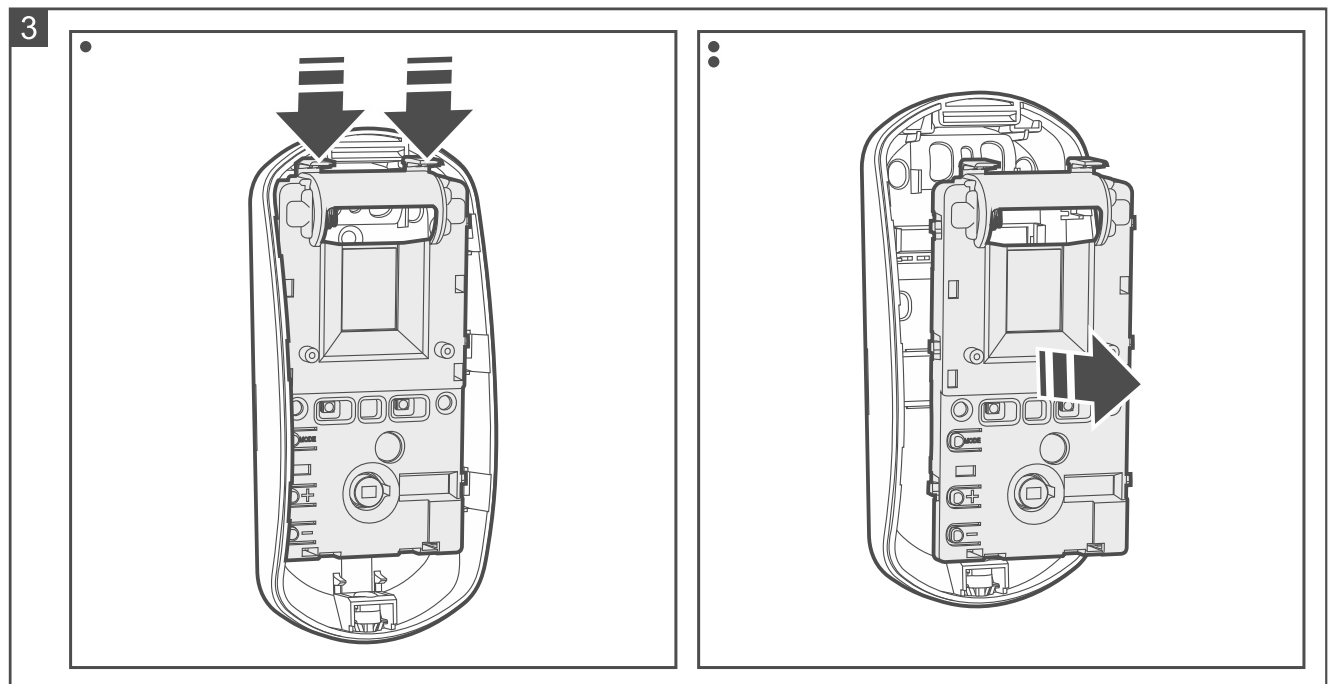

3. If the detector is to be mounted on the wall using a double-sided mounting tape (Fig. 4):
- stick the tape to the enclosure base. Adjust the shape and position of the tape depending on the place of installation.
  - stick the enclosure base to the wall.

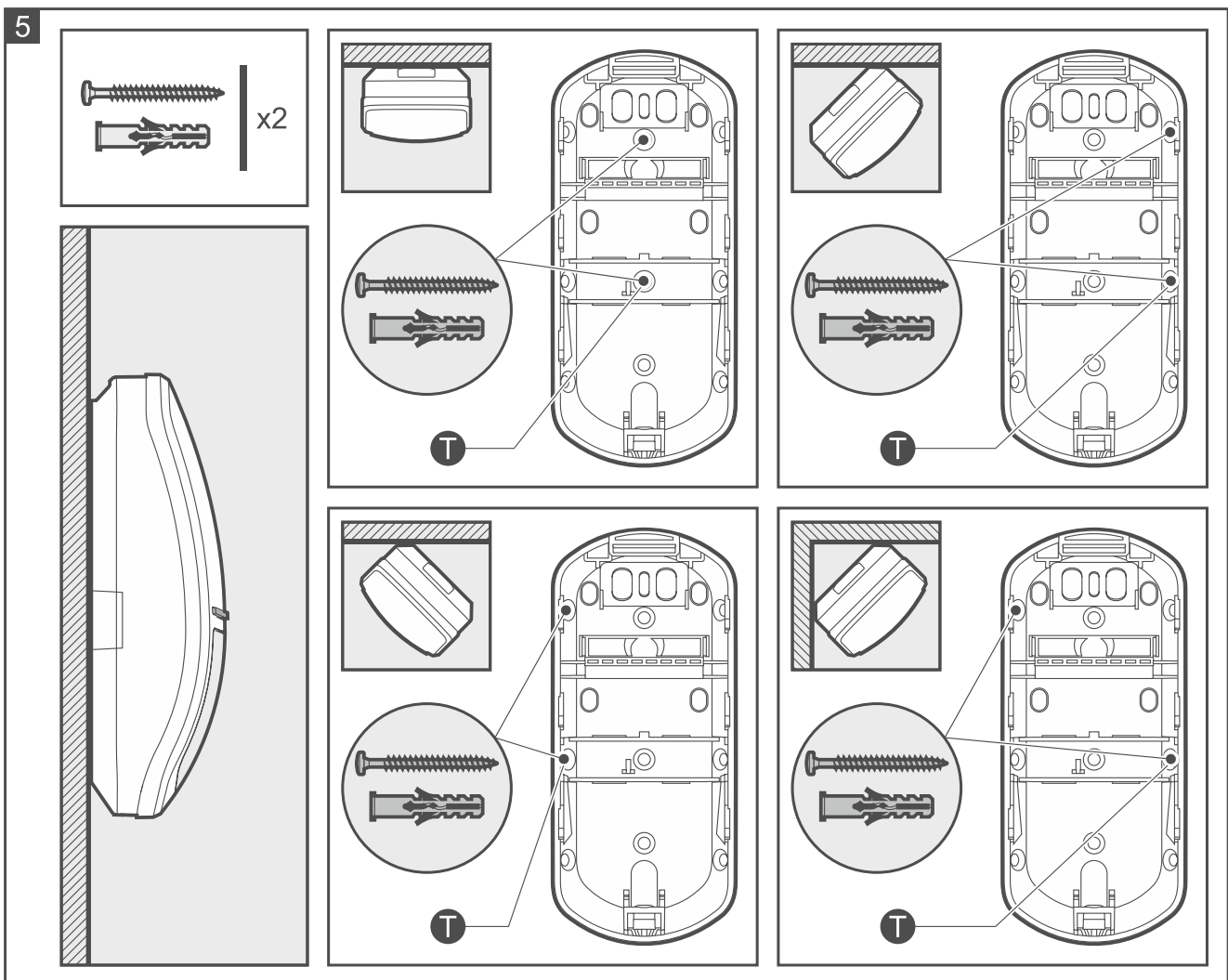
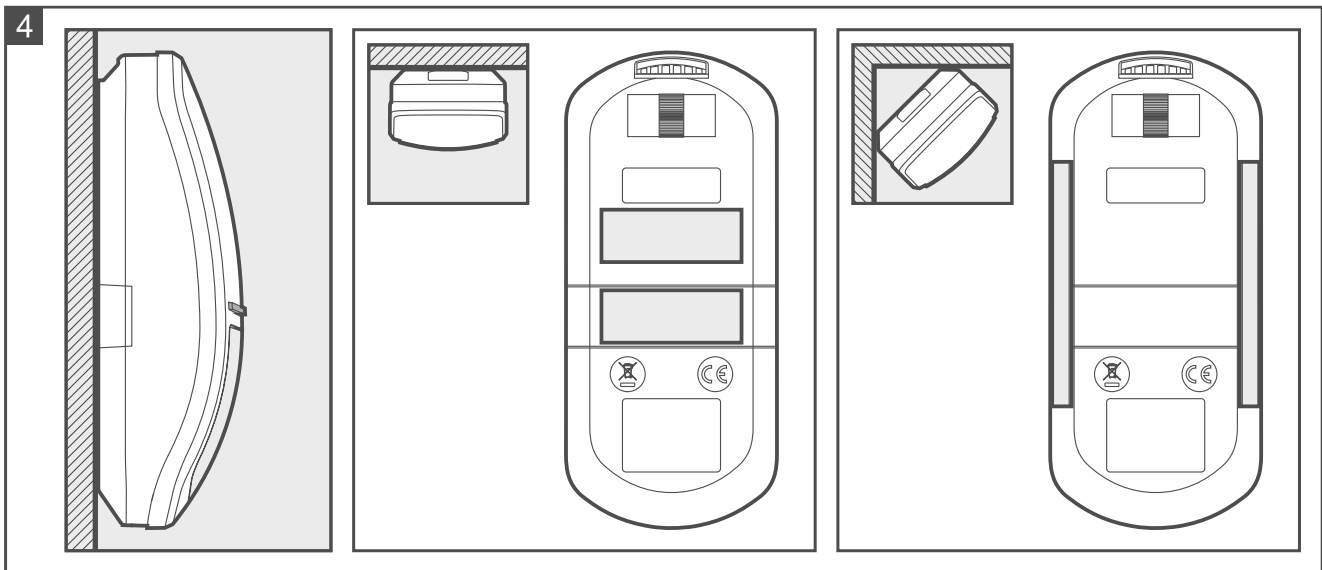

4. If the detector is to be secured to the wall with screws (Fig. 5):
- make screw holes in the enclosure base.

- drill the holes in the wall for wall plugs (anchors). The wall plugs provided with the detector are intended for concrete or brick. For other types of surface (drywall, styrofoam), use other appropriately selected wall plugs.
- secure the enclosure base to the wall with screws.



*If the detector is to detect removal from the surface, secure the detector to the wall with screws. In order for the detector to detect removal from the surface, fasten the screw in place marked with the **T** symbol in Fig. 5.*

*The detector must detect removal from the surface if it is to meet the requirements of Standard EN 50131 for Grade 2.*

5. Add the detector to the system (see the manual for the BE WAVE system controller or the BE WAVE Hybrid system control panel). When a request to turn on the device will be displayed, install the battery in the detector.
6. Place the electronics module in the enclosure base and then move it up to lock it.
7. Replace the cover.

## 4. Test

1. Enable the diagnostics mode in the system (see the manual for the BE WAVE system controller or the BE WAVE Hybrid system control panel).
2. Check if moving within the detector coverage area will make the LED indicators turn ON. Figure 6 shows the maximum coverage area of the detector.
3. Disable the diagnostics mode.

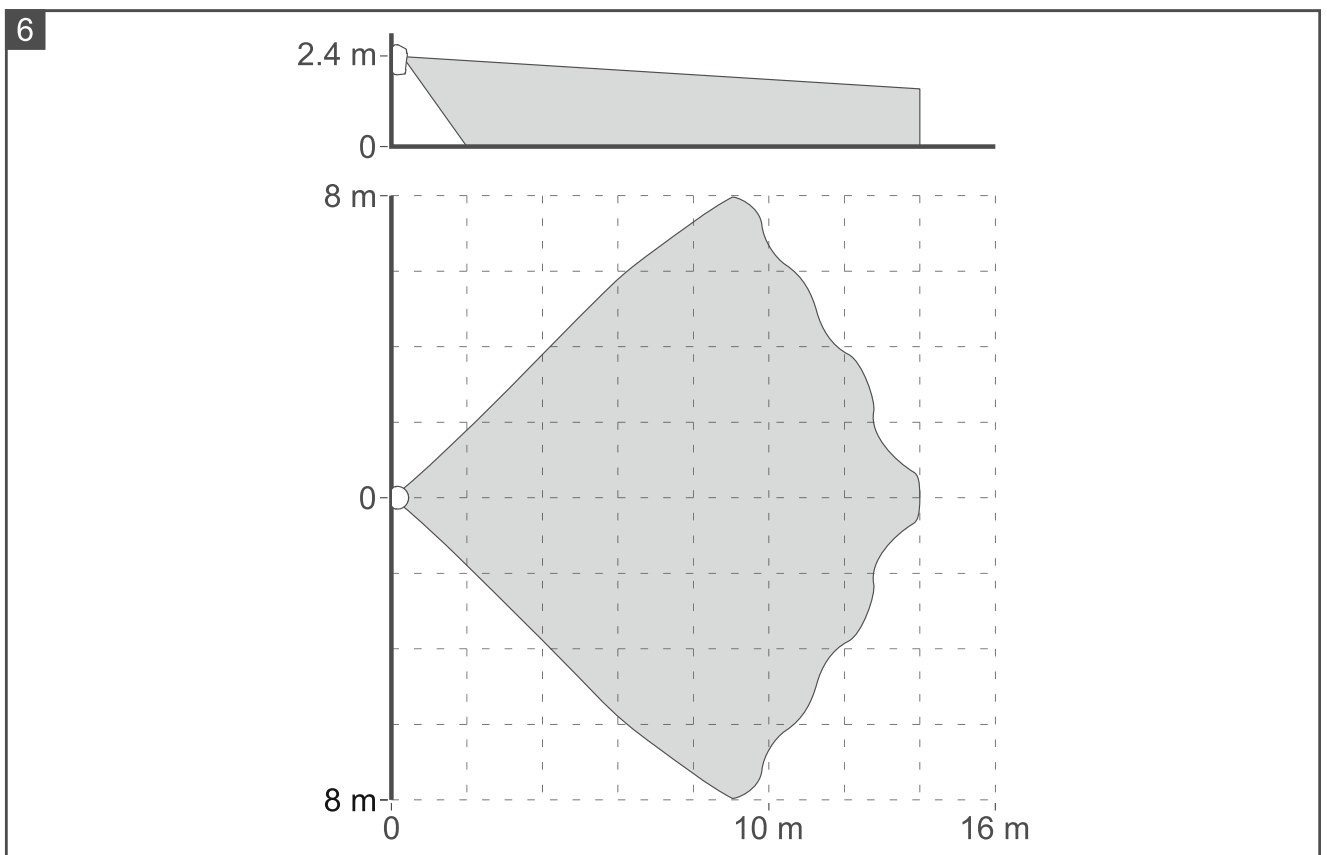

## 5. Battery replacement

---



**The used batteries must not be discarded, but should be disposed of in accordance with the existing rules for environment protection.**

The Be Wave app will indicate that the battery in the detector is low. The low battery should be replaced as soon as possible.

1. In the Be Wave app / BE WAVE Soft program, tap / click the room in which the detector is installed.
2. Tap / click the detector name.
3. Start the *Battery replacement* function.
4. Remove the front cover.
5. Remove the low battery.
6. Wait 1 minute.
7. Install the new battery.
8. Replace the cover.
9. Start the *Unbypass device* function in the Be Wave app / BE WAVE Soft program.

## 6. Specifications

---

Operating frequency band.....	868.0 MHz ÷ 868.6 MHz
Radio communication range (in open area) .....	up to 1800 m
Battery.....	CR123A 3 V
Battery life expectancy .....	up to 2 years
Standby current consumption .....	70 µA
Low battery voltage threshold .....	2.75 V
Temperature measurement range .....	-10°C...+55°C
Temperature measurement accuracy .....	±1°C
Detectable speed .....	0.3...3 m/s
Warm-up period .....	35 s
Recommended installation height .....	2.4 m
Maximum coverage area.....	14 m x 16 m, 83°
Complied with standards.....	EN 50131-1, EN 50130-4, EN 50130-5
Security grade according to EN 50131-2-2 .....	Grade 2
Environmental class according to EN 50130-5 .....	II
Operating temperature range.....	-10°C...+55°C
Maximum humidity .....	93±3%
Dimensions .....	62 x 137 x 42 mm
Weight.....	107 g