

Satel®

abax2

ASD-250

Wireless smoke detector

CE

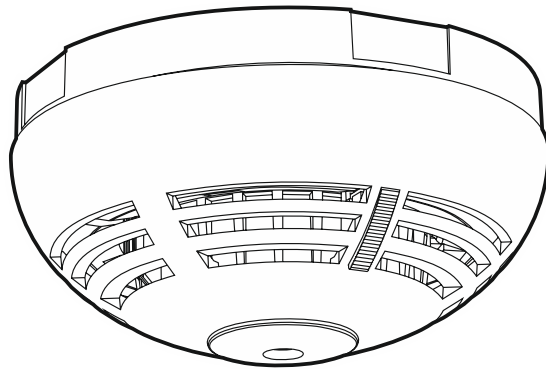

Firmware version 1.00

asd-250_en 03/21

SATEL sp. z o.o. • ul. Budowlanych 66 • 80-298 Gdańsk • POLAND
tel. +48 58 320 94 00
www.satel.eu

IMPORTANT

Prior to installation, please read carefully this manual in order to avoid mistakes that can lead to malfunction or even damage to the equipment.

Changes, modifications or repairs not authorized by the manufacturer shall void your rights under the warranty.

The rating plate of the device is located inside the enclosure.

SATEL aims to continually improve the quality of its products, which may result in changes in their technical specifications and software. Current information about the changes being introduced is available on our website.

Please visit us at:
<https://support.satel.eu>

Hereby, SATEL sp. z o.o. declares that the radio equipment type ASD-250 is in compliance with Directive 2014/53/EU. The full text of the EU declaration of conformity is available at the following internet address: www.satel.eu/ce

In the EU, this radio equipment is only permitted to operate in the 868 MHz frequency band.

The following symbols may be used in this manual:



- note,



- caution.

The ASD-250 detector can detect the early stages of fire development when there is some visible smoke. It can operate as a stand-alone device or within the ABAX 2 / ABAX two-way wireless system. This manual applies to the detector with firmware version 1.00, which is supported by:

- ABAX 2:
 - ACU-220 / ACU-280 controller,
 - ARU-200 repeater.
- ABAX:
 - ACU-120 / ACU-270 controller (firmware version 5.04 or newer),
 - ARU-100 repeater (firmware version 2.02 or newer),
 - INTEGRA 128-WRL control panel (firmware version 1.19 or newer and firmware version of processor used to operate ABAX system 3.10 or newer).

1. Features

- EN 14604 compliant visible smoke sensor.
- Detection of optical chamber fouling.
- Test feature.
- Built-in sounder.
- LED for optical signaling.
- Battery status control.
- “ECO” option for longer battery life (ABAX 2 system only).
- Encrypted two-way radio communication in the 868 MHz / 915 MHz frequency band (AES standard for the ABAX 2 system).
- Transmission channel diversity – 4 channels for automatic selection of the one that will enable transmission without interference with other signals in the 868 MHz / 915 MHz frequency band (ABAX 2 system only).
- Tamper protection against enclosure opening (when used in the ABAX 2 / ABAX system).

2. Description

Fire alarm

Smoke detection

An optical method is used for the detection of visible smoke. When the concentration of smoke in the optical chamber exceeds a given threshold, a fire alarm is triggered. The detector automatically compensates for gradual changes in the optical chamber caused by deposition of dust.

Fire alarm signaling

The alarm is indicated visually (LED steady light) and acoustically (continuous sound) for 5 minutes. Pressing the test / reset button (Fig. 1) during the alarm will clear the alarm condition and will block the smoke detection function in the detector for 5 minutes.



The detector working in the ABAX 2 / ABAX system can signal alarm triggered by another detector. For more information, refer to the manual of ABAX 2 / ABAX controller / INTEGRA 128-WRL control panel.

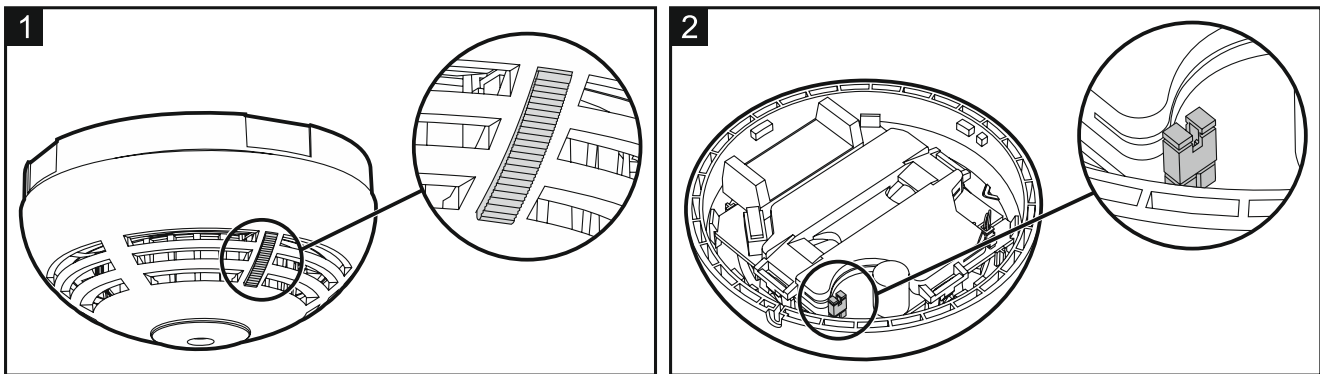

Operating modes

You can set the operating mode using the jumper located on the printed circuit board (Fig. 2):

- jumper removed – stand-alone mode.
- jumper installed – working in ABAX 2 / ABAX system. The detector is operating similarly as in the stand-alone mode, but it additionally:
 - communicates with the ABAX 2 / ABAX controller / INTEGRA 128-WRL control panel,
 - supervises the tamper switch state.

Detector test

If you want to test operation of the detector, press the test / reset button (Fig. 1). A short sound will be heard. After a few seconds, the fire alarm should be triggered.

LED

Behavior of the LED depends on the selected operating mode.

Stand-alone mode

LED indicates:

- optical chamber soiling – 2 short flashes every 30 seconds,
- low battery – 3 short flashes every 30 seconds,
- alarm – ON for 5 minutes.

Working in ABAX 2 / ABAX system

LED indicates:

- low battery – 3 short flashes every 30 seconds,
- alarm – ON for 5 minutes.

When the ABAX 2 / ABAX system is running in the test mode, the LED indicates additionally:

- periodical communication – short flash (80 milliseconds), and when the chamber is soiled - 2 short flashes,
- alarm memory – flashing rapidly.

Detection of optical chamber soiling

The detector is monitoring the state of the optical chamber. Deposition of dust in it may lead to malfunctioning of the device. When the optical chamber requires cleaning, this state is indicated by the LED.

Battery status control

When the battery voltage is lower than 2.75 V, the detector indicates low battery: 3 short flashes of LED and 3 short beeps every 30 seconds. If the detector is working in the ABAX 2

/ ABAX system, the low battery info is sent during each transmission to the controller / control panel.

Working in ABAX 2 / ABAX system

Radio communication

The detector connects to the controller / control panel at regular time intervals to provide information about its state (periodical communication). Additional communication takes place in the case of alarm (smoke is sensed by the detector) or tamper (tamper switch has been opened) and after restore of alarm (smoke is sensed no more by the detector) or tamper (tamper switch has been closed).

Test mode

The test mode makes diagnostics of the detector easier, because the detector LED indicates periodical communication and alarm memory. How to start and end the test mode is described in the ABAX 2 / ABAX controller manual / the INTEGRA 128-WRL control panel manual.



The alarm memory is cleared after ending the test mode.

Energy saving mode (ECO)

If you want to prolong the battery life, you can enable in the detector the “ECO” option. When the “ECO” option is enabled, the periodical communication takes place every 3 minutes. Thus the battery life can be increased as much as fourfold. The option is only available in the ABAX 2 system.

3. Selecting a mounting location

- The detector is designed for indoor installation.
- The detector should be installed in location close to the building / apartment exit (e.g. in the hall, lobby etc. – Fig. 3 and Fig. 4).
- In the typical home or office applications, the detector should be installed on the ceiling, as close as possible to the center of the room, at a distance of at least 0.5 meters from the walls or other objects (Fig. 5).
- Do not install the detector in places with high concentration of dust and/or formation and condensation of water steam.
- Do not install the detector near heaters, cookers, fans or air-conditioner outlets.
- Do not install the detector in places where there is no unobstructed movement of air (e.g. in recesses, niches, etc.).
- If the detector is to be used as part of the ABAX 2 / ABAX system, it is not advisable to install it in close vicinity of electrical systems, because it can adversely affect the range of radio signal.

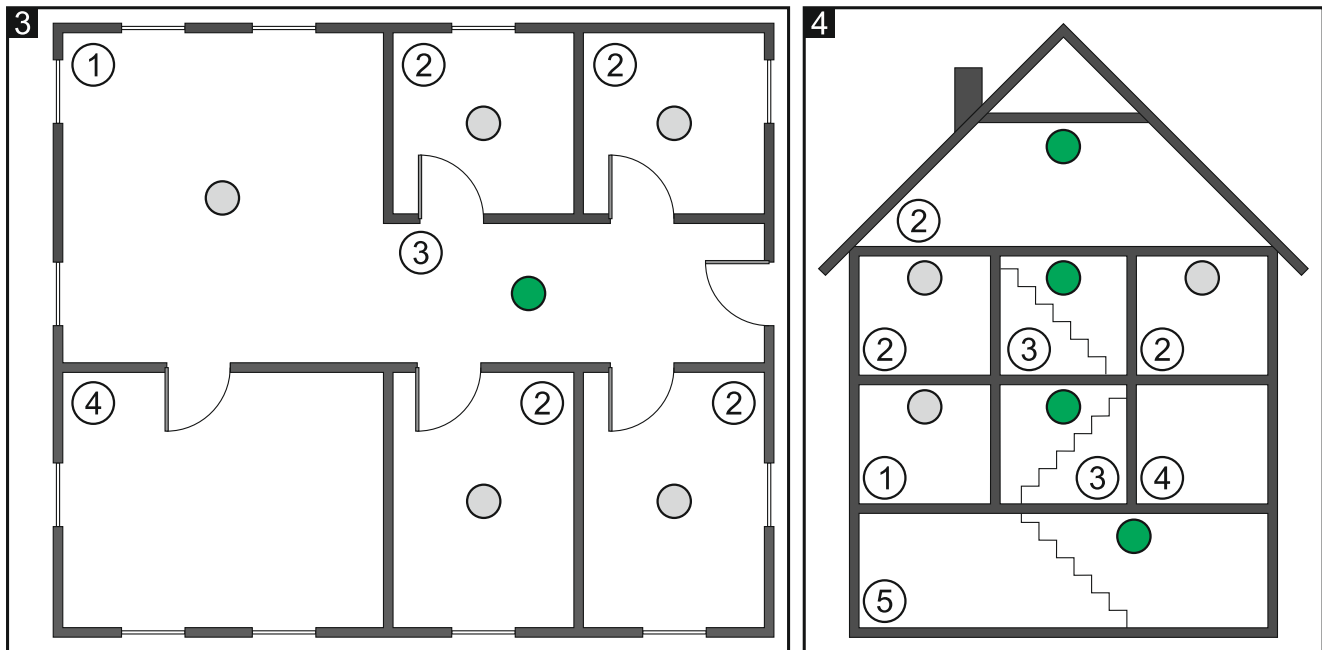

Legend for Figures 3 and 4:

- ① living room.
- ② room.
- ③ hall, lobby, etc.
- ④ kitchen.
- ⑤ basement.
- basic location for detector installation.
- additional location for detector installation.

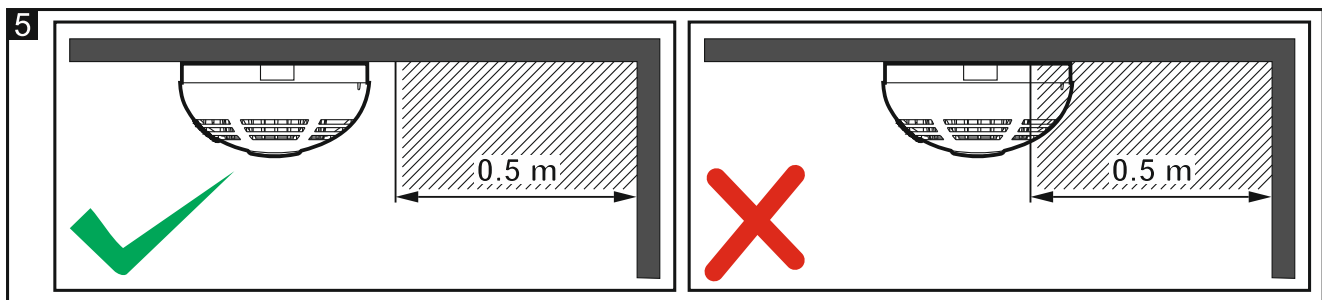

4. Installation



The detector enclosure can not be closed without the battery inserted.

Do not install the battery if the sounder is disconnected.

There is a danger of battery explosion when using a different battery than recommended by the manufacturer, or handling the battery improperly.

Be particularly careful during installation and replacement of the battery. The manufacturer is not liable for the consequences of incorrect installation of the battery.

1. Remove the plastic dust cap.

2. Turn the cover counter-clockwise (Fig. 7) and remove it (Fig. 8).
3. If the detector is to work as a stand-alone device, remove the jumper (Fig. 2) and skip the steps 5-9.



After the battery is installed, removing / placing the jumper will have no effect on the detector operation.

4. Install the battery.
5. Add the detector to the wireless system (see the ABAX 2 / ABAX controller manual or the INTEGRA 128-WRL control panel installer manual). The sticker with serial number which shall be entered when registering the detector in the system can be found on the electronics module.



In the INTEGRA / VERSA alarm system, the detector is identified as ASD-150.

Simultaneous operation of the detector by the ABAX 2 and ABAX controller / INTEGRA 128-WRL alarm control panel is not possible.

6. Close the detector enclosure.
7. Put the detector at the place of its future installation.
8. Check the level of signal received from the detector by the ABAX 2 / ABAX controller or the INTEGRA 128-WRL control panel. If the signal level is lower than 40%, select another place for installation. Sometimes, it is sufficient to shift the device ten or twenty centimeters to obtain a considerable improvement in the signal quality. You can also try to turn the enclosure to check what effect the change of antenna position will have on the signal strength.



The ARF-200 tester makes it possible to check the radio signal strength at the place of future installation without having to put the detector there.

9. Remove the detector cover.
10. Use wall plugs (anchors) and screws to secure the enclosure base to the ceiling. The wall plugs delivered with the device are intended for concrete, brick, etc. For other types of surface (drywall, styrofoam), use the appropriately selected wall plugs.
11. Replace the detector cover and lock it with the screw.
12. Press the test / reset button (Fig. 1). Fire alarm should be triggered.
13. If in the premises where the detector is installed, any work is being carried out that may lead to soiling of the optical chamber, put a plastic dust cover on the detector and leave it there until the work is finished.

5. Maintenance

The detector should be subjected to regular checks for correct functioning. The periodic checks should be carried out at least every 6 months. To check whether the detector is operating properly, press the test / reset button (Fig. 1). This should trigger a fire alarm.

6. Cleaning the optical chamber

It is recommended that you have the optical chamber cleaned at least once a year. Cleaning the chamber is necessary when the LED indicates fouling of the chamber (operation within the ABAX 2 / ABAX system – 2 short flashes during periodical communication with controller / control panel; stand-alone mode – 2 short flashes every 30 seconds).

1. Start the service mode in the control panel (if the controller is connected to a SATEL alarm control panel).

2. Remove the screw fastening the cover (Fig. 6).
3. Turn the cover counter-clockwise (Fig. 7) and remove it (Fig. 8).

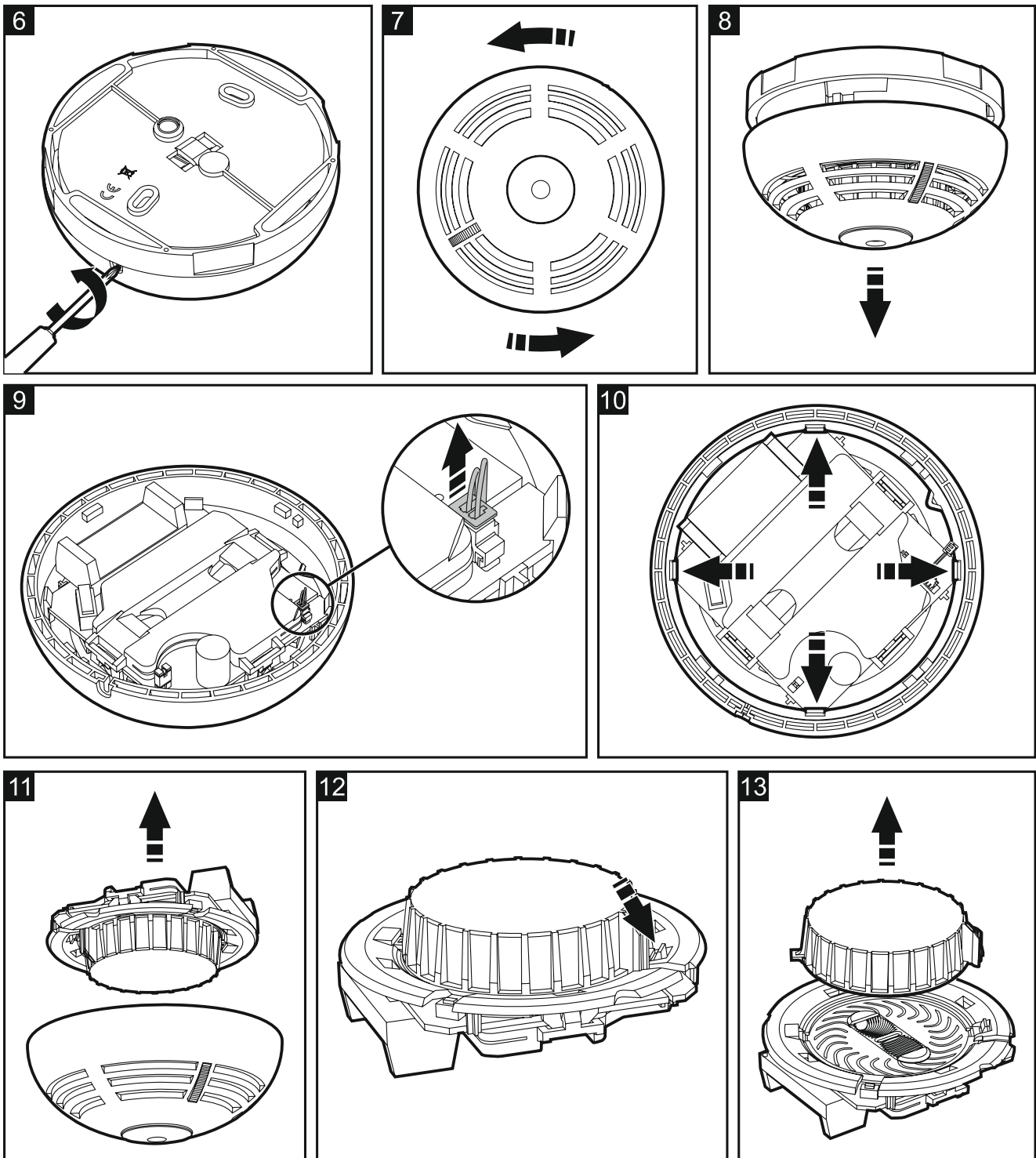

4. Remove the battery.
5. Disconnect the plug connecting the sounder wires with the electronics board (Fig. 9).
6. Push outward the catches (Fig. 10) and take out the electronics module with the optical chamber (Fig. 11).
7. Push outward the catch securing the optical chamber cover (Fig. 12) and remove it (Fig. 13).
8. Using a soft brush or compressed air, clean the labyrinth in the cover, as well as the base of the optical chamber, paying attention to the recesses where LEDs are installed.

9. Replace the cover of the optical chamber.
10. Lay the sounder wires in their corresponding grooves.
11. Secure the electronics module with the optical chamber in the cover mounting catches. The board must be mounted so that the LED coincides with the light guide.
12. Reconnect the plug connecting the sounder wires with the electronics board.
13. Re-install the battery.
14. Replace the detector cover and lock it with the screw.
15. Press the test / reset button (Fig. 1). Fire alarm should be triggered.

7. Battery replacement



The used batteries must not be discarded, but should be disposed of in accordance with the existing rules for environment protection.

When the detector indicates low battery (3 short flashes of the LED and 3 short beeps every 30 seconds), the battery must be replaced.

1. Start the service mode in the control panel (if the controller is connected to a SATEL alarm control panel).
2. Remove the screw fastening the cover (Fig. 6).
3. Turn the cover counter-clockwise (Fig. 7) and remove it (Fig. 8).
4. Remove the discharged battery.
5. Install a new CR123A 3 V lithium battery.
6. Replace the detector cover and lock it with the screw.
7. Press the test / reset button (Fig. 1). Fire alarm should be triggered.

8. Specifications

| | |
|--|---|
| Operating frequency band | 868.0 MHz ÷ 868.6 MHz / 915 MHz – 928 MHz |
| Radio communication range (in open area) | |
| ABAX 2 | |
| ACU-220 | up to 2000 m |
| ACU-280 | up to 1200 m |
| ABAX..... | up to 500 m |
| Battery | CR123A 3 V |
| Battery life expectancy | |
| ABAX 2 / ABAX..... | up to 2 years |
| stand-alone mode | up to 4 years |
| Standby current consumption | |
| ABAX 2 / ABAX..... | 90 µA |
| stand-alone mode | 15 µA |
| Maximum current consumption..... | 120 mA |
| Operating temperature range..... | 0°C...55°C |
| Maximum humidity | 93±3% |
| Dimensions | ø108 x 54 mm |
| Weight..... | 170 g |

The ASD-250 wireless smoke detector conforms to the essential requirements of the EU Regulations and Directives:

CPR 305/2011 Regulation of the European Parliament and of the Council of 9 March 2011 laying down harmonized conditions for the marketing of construction products and repealing the Council Directive 89/106/EEC on construction products;

RED Directive 2014/53/EU of the European Parliament and of the Council of 16 April 2014 on the harmonization of the laws of the Member States relating to the making available on the market of radio equipment and repealing Directive 1999/5/EC.

The CNBOP-PIB Certification Body in Józefów issued the Certificate of Constancy of Performance 1438-CPR-0645 for the construction product ASD-250 Wireless Smoke Detector, confirming its compliance with the requirements of EN 14604:2006.

The CNBOP-PIB Certification Body in Józefów has tested the AS-250 Wireless Smoke Detector confirming its compliance with the EN 14604 Standard, within the scope of Appendix L (approved for the use in caravans and camper vans).

The Certificate and the Declaration of Performance can be downloaded from the www.satel.eu website.



SATEL Sp. z o.o. • ul. Budowlanych 66 • 80-298 Gdańsk • POLAND

1438

1438-CPR-0645

DOP/CPR/0645

EN 14604

Fire safety. ASD-250 wireless, stand-alone smoke detector, capable of interacting via radio with an intrusion and hold-up alarm system, operating based on the light scattering principle, for use in buildings.

Declaration of Performance DOP/CPR/0645

Application – fire safety.

Technical specifications – please refer to this manual.